

REVISIONS					
REV.	DESCRIPTION	RFC	DATE	AUTHOR	CHECKED BY
A	Released for manufacture		23/04/2018		
B	Base plate size changed		10/05/2018		

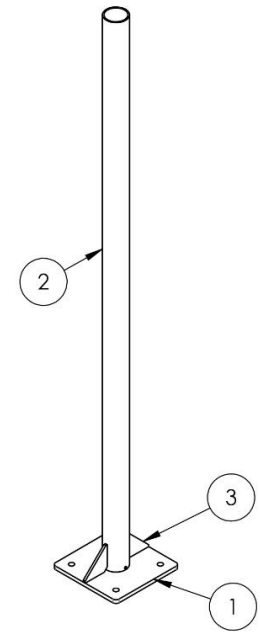

ALL WELDING CONTINUOUS 6mm FILLET WELD UNLESS SPECIFIED OTHERWISE

ITEM NO.	MATERIAL	DESCRIPTION	LENGTH	QTY.
1	BHP - 300 PLUS	200x10 FL	200	1
2	AS 1163-350	60.3x3.6 CHS	1500	1
3	BHP - 300 PLUS	70x6 Profile plate	70	2

DO NOT SCALE DRAWING
UNLESS OTHERWISE SPECIFIED:
DIMENSIONS ARE IN MILLIMETERS

TOLERANCES:
0 DEC ± 2.0
1 DEC ± 1.0
2 DEC ± 0.5
ANGULAR: ± 2.0°



	NAME	DATE	SIGNATURE
DRAWN		23/04/18	
CHECK'D		23/04/18	
APP'VD	-	23/04/18	

MATERIAL:
AS PER REQUIREMENTS ON
ORDER FORM AND
DRAWING No.
'EZYSTRUT MATERIAL SPEC'

FINISH:
HOT DIP GALV (HDG) TO
AS/NZS 4680, ISO 1461

DEBUR AND BREAK SHARP EDGES

PROJECT:	E4796	A3
TITLE:	Single instrument support	
DRAWING NO.	E4796-001	REV. B

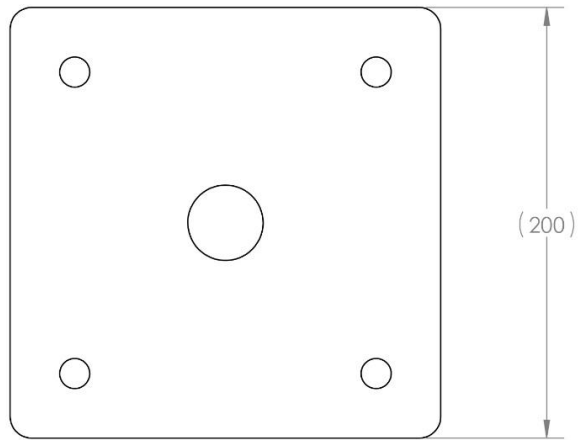

Item 1 - 10mm profile plate

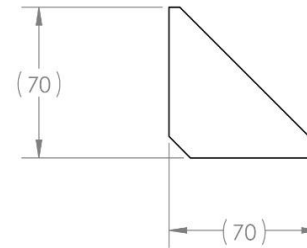

Item 3 - 6mm profile plate

DO NOT SCALE DRAWING
UNLESS OTHERWISE SPECIFIED:
DIMENSIONS ARE IN MILLIMETERS

TOLERANCES:
0 DEC ± 2.0
1 DEC ± 1.0
2 DEC ± 0.5
ANGULAR: ± 2.0*



MATERIAL:
AS PER REQUIREMENTS ON
ORDER FORM AND
DRAWING No.
'EZYSTRUT MATERIAL SPEC'

FINISH:
HOT DIP GALV (HDG) TO
AS/NZS 4680, ISO 1461

DEBUR AND BREAK SHARP EDGES

PROJECT: **E4796** **A3**

TITLE: **Single instrument support**

DRAWING NO. **E4796-001** REV. **B**