

# Thermo Scientific Ramsey Series 14

## Precision Belt Scale System

The Thermo Scientific™ Ramsey™ Series 14 precision belt scale system is specifically designed for high accuracy or basis-of-payment applications requiring certification by government and regulatory agencies. It is extremely accurate to within +/-0.125% and is the most widely certified belt scale in the world. This precision belt scale system lets you monitor production output and inventory, or regulate product loadout, while providing vital information for the effective management and efficient operation of your business.



The Ramsey Series 14 precision belt scale system is specifically designed for high-accuracy or basis-of-payment applications requiring certification by government and regulatory agencies.

The Ramsey Series 14 belt scale system incorporates the Thermo Scientific™ Ramsey™ 10-14 low-deflection, full-floating unitized weighbridge and the Thermo Scientific™ Ramsey™ 61-12C Belt Speed Sensor. Both are well-proven on hundreds of precision belt weighing installations.

It also utilizes the Thermo Scientific™ Ramsey™ Micro-Tech 9301 electronic integrator and the Thermo Scientific™ Ramsey™ 9301-D load cell exciter/digitizer, which are the products of 50 years of design and application experience with high-accuracy belt scales.

### Applications

This highly precise belt scale system represents the world standard of accuracy and performance for loadout, inventory monitoring and fee-holder type applications requiring certification.

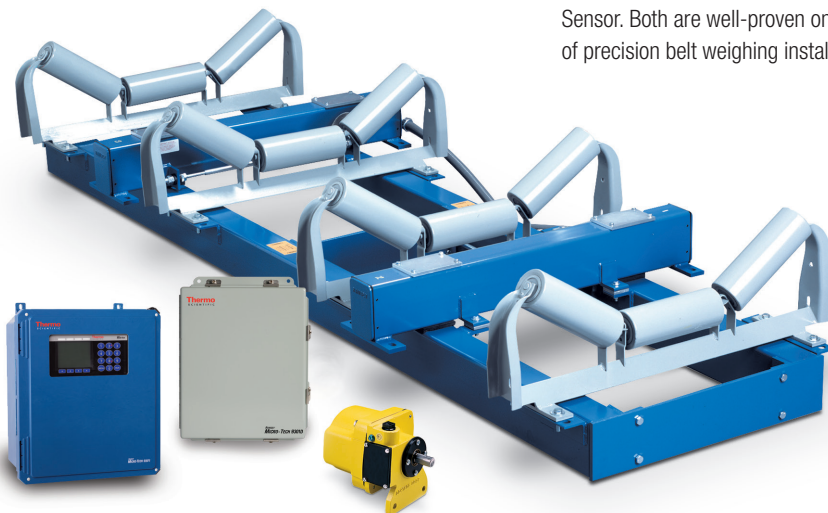

**Thermo**  
SCIENTIFIC

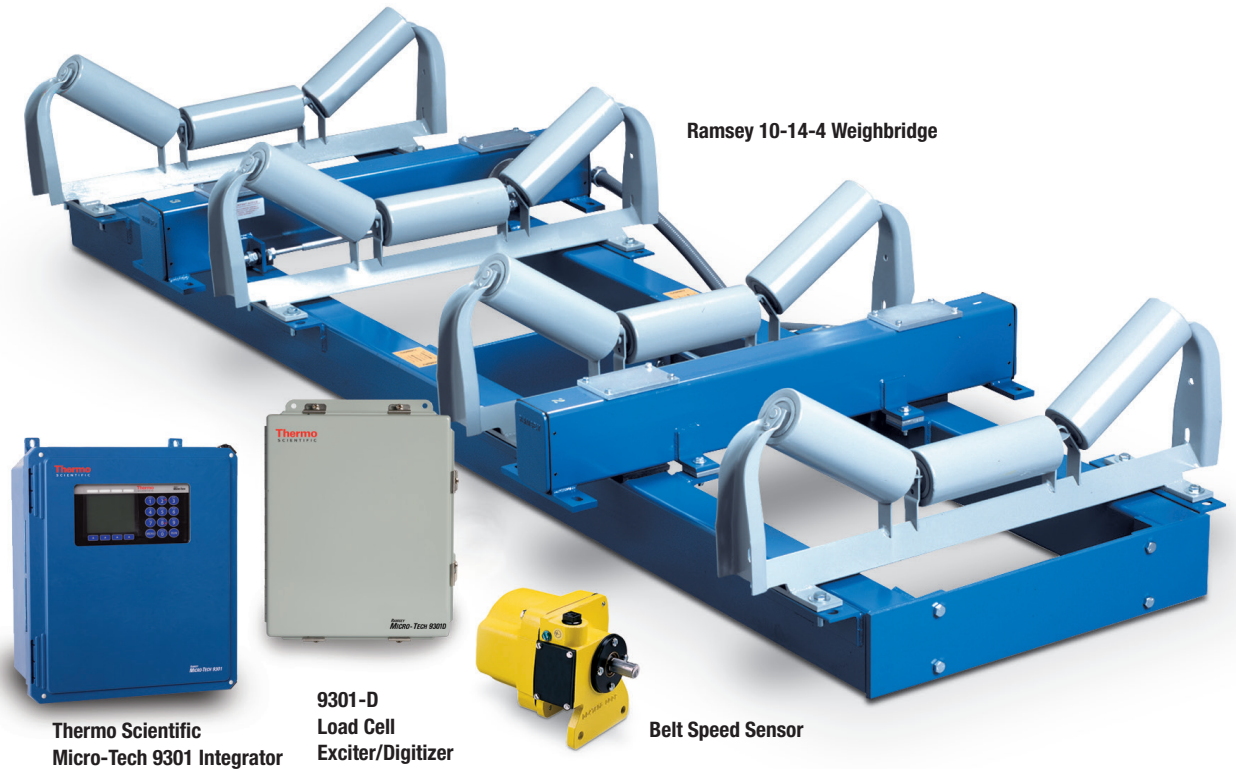

Ramsey 10-14-4 Weighbridge

Thermo Scientific  
Micro-Tech 9301 Integrator

9301-D  
Load Cell  
Exciter/Digitizer

Belt Speed Sensor

## Features & Benefits

### Certification

As the most widely certified electronic belt scale in the world, the Ramsey Series 14 has received its Certificate of Conformance in the United States as issued under the National Type Evaluation Program (NTEP) of the National Conference on Weights and Measures. Additional approvals and certifications are pending.

### System Components

The system has four major components: integrator, weighbridge, belt speed sensor and load cell digitizer.

### The Weighbridge

Three- or four-idler suspension-type Ramsey 10-14 weighbridges feature full-floating unitized assemblies with no pivots and no moving parts.

All weighbridges are constructed of structural steel tubing and are factory pre-assembled with checkrods to facilitate fast and easy field installation. Only eight bolts are required to mount the unit to conveyor stringers. Four environmentally-sealed precision strain gauge load cell assemblies are applied in tension to support the weighbridge.

### The Belt Speed Sensor

The Ramsey 61-12C digital belt speed sensor is the most reliable and accurate

speed-sensing device ever developed for belt scale service. Direct-coupling the sensor to the conveyor tail pulley, snubbing roll, or a large diameter return roller ensures an accurate belt-travel readout. No wheels ride on the belt, which eliminates problems related to material build-up and slippage.

### The Exciter/Digitizer

The Ramsey 9301-D load cell exciter/digitizer serves as an interface from the Ramsey 10-14 weighbridge to the Ramsey Micro-Tech 9301 integrator. The unit powers the load cells and converts the analog output signals from the strain gauge load cells to an accurate, stable digital output, which provides extraordinary temperature stability. And because the output signal is digitized at the load cell, line loss is virtually eliminated and signal integrity is maintained. This unique feature is particularly important in applications where the integrator is located up to 1,219 m (4,000 ft) from the carriage.

### Weighbridge Advantages

- Rigid structural steel tubing construction with checkrods maintains positive alignment
- No moving or wearing parts lead to a longer life span
- No adjustments needed
- Factory pre-assembled and easily installed

- Four strain gauge load cells applied in tension
- Full-floating, pivotless weigh platform

### Belt Speed Sensor Advantages

- Rugged, cast-aluminum housing suitable for outdoor installations
- A.C. pulse generator means no brushes to adjust or replace

### Exciter/Digitizer Advantages

- Housed in a NEMA 4 painted, mild steel enclosure
- No adjustments or calibration required
- Digital accuracy
- Extraordinary temperature stability

### Performance Guarantee

On factory-approved installations, we warrant that the Ramsey Series 14 precision belt scale system will weigh and totalize to a value within  $\pm 0.125\%$  of the test load at flow rates between 25% and 100% of the scale system's calibrated capacity when calibrated against an actual weighed material test. Furthermore, we warrant that the scale system will repeat to within 0.1% of consecutively run, simulated calibration tests.

Ramsey Series 14 Precision Belt Scale – Four-Idler Weighbridge Dimensions

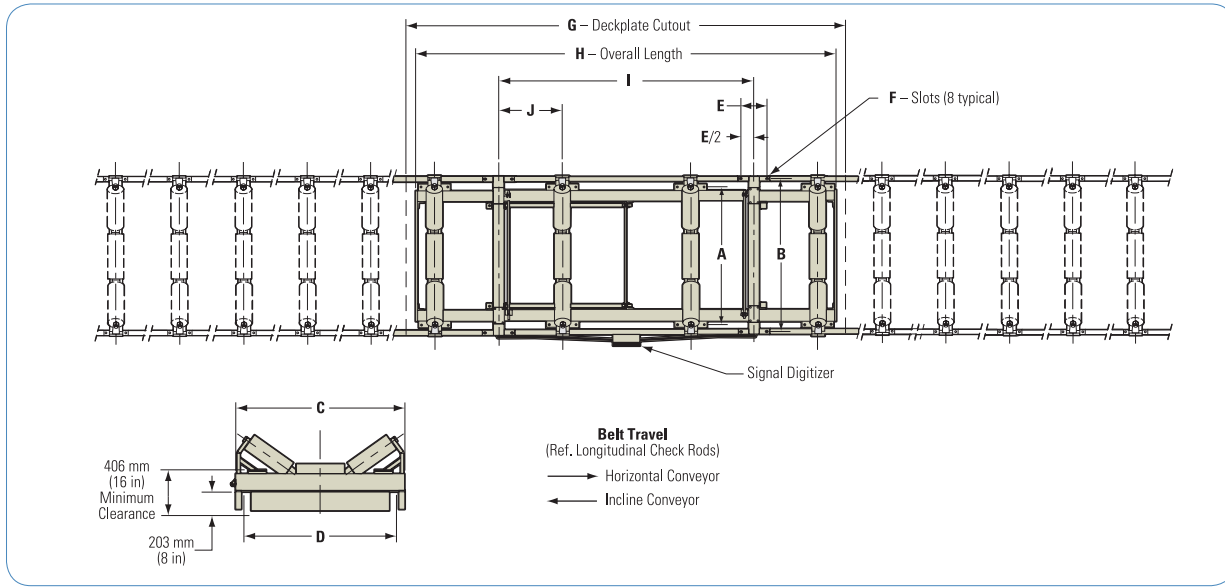

Ramsey Series 14 Precision Belt Scale – Variable Belt Width Dimensions

BELT WIDTH	LENGTH (in)					
	A	B	C	D	E	F
18 in	21.25	27	29.5	23.25	7.5	0.56 x 1
20 in	23.25	29	31.5	25.25	7.5	0.56 x 1
24 in	27.25	33	35.5	29.25	7.5	0.56 x 1
30 in	33.25	39	41.5	35.25	7.5	0.56 x 1
36 in	39.25	45	47.5	41.25	7.5	0.56 x 1
42 in	45.25	51	53.5	47.25	10	0.81 x 1
48 in	51.25	57	59.5	53.25	10	0.81 x 1
54 in	57.25	63	65.5	59.25	10	0.81 x 1
60 in	63.25	69	71.5	65.25	10	0.81 x 1
72 in	75.25	81	83.5	77.25	10	0.81 x 1
84 in	87.25	93	95.5	89.25	10	0.81 x 1

BELT WIDTH	LENGTH (mm)					
	A	B	C	D	E	F
457 mm	540	686	749	591	191	1.43 x 25.4
508 mm	591	737	800	641	191	1.43 x 25.4
610 mm	692	838	902	743	191	1.43 x 25.4
762 mm	845	991	1054	895	191	1.43 x 25.4
914 mm	743	1143	1207	1048	191	1.43 x 25.4
1067 mm	1149	1295	1359	1200	254	2.06 x 25.4
1219 mm	1302	1448	1511	1353	254	2.06 x 25.4
1372 mm	1454	1600	1664	1505	254	2.06 x 25.4
1524 mm	1607	1753	1816	1657	254	2.06 x 25.4
1829 mm	1911	2057	2121	1962	254	2.06 x 25.4
2134 mm	2216	2362	2426	2267	254	2.06 x 25.4

Ramsey 9301-D Load Cell Exciter/Digitizer Dimensions

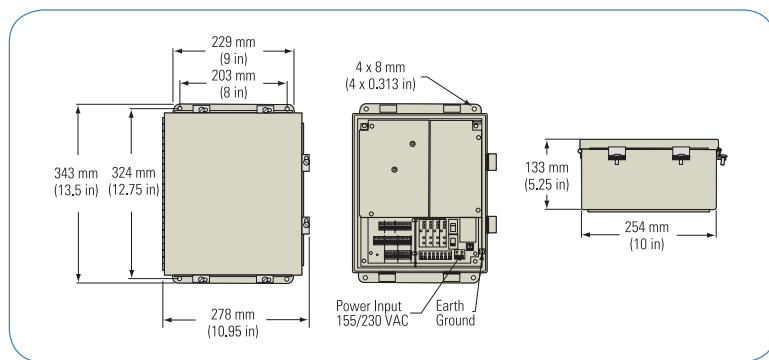

Ramsey Micro-Tech 9301 Belt Conveyor Scale Integrators Dimensions

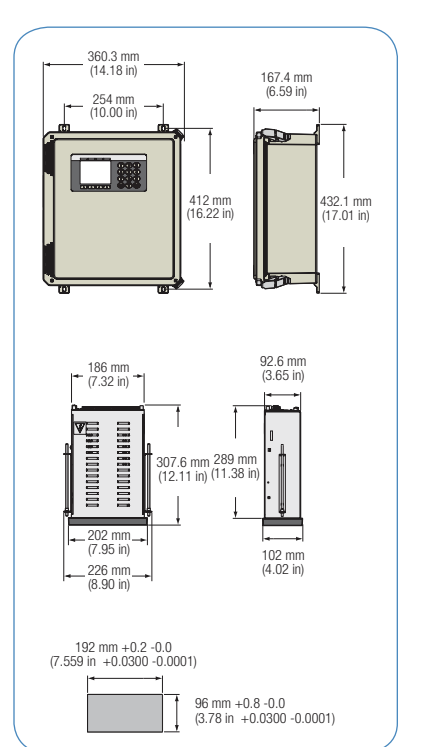

Ramsey 61-12 Speed Sensor Dimensions

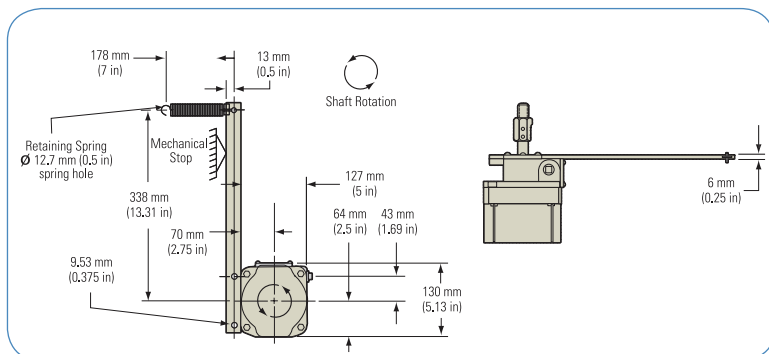

## Thermo Scientific Ramsey Series 14

### Ramsey 10-14 Weighbridges Specifications

Weigh Span	Three- or four-idler suspension; 2,743 mm (108 in) minimum weigh span
Clearance Requirements	Fits any standard conveyor; No space required above belt line
Idlers	Normally furnished by customer; Thermo Fisher Scientific can supply idlers upon request
Conveyors Sizes	457 mm to 2,134 mm (18 in to 84 in) or 400 mm to 2,000 mm (15.75 in to 78.75 in) belt widths
Weighbridge Construction	Mechanical steel tubing
Weighbridge Mounting	Eight bolts (four per support beam) to conveyor stringers

### Ramsey Micro-Tech 9301 Electronics Specifications

Enclosure	Field mount, NEMA-4X fiberglass, IP66, dust and watertight, 432 mm (17 in) x 360 mm (14 in) x 167 mm (6.6 in) Panel mount, chromate mild steel chassis, front panel IP65, DIN 43700, 308 mm (12 in) x 102 mm (4 in) x 202 mm (7.9 in)
Temperature	Operating: -20°C to +60°C (-4°F to +140°F) Storage: -30°C to +70°C (-22°F to +158°F)
Power Requirements	Field mount: 100-240 VAC, 50/60 Hz Panel mount: 24 VDC +10%, -15% (user supplied), 24 VDC only, optional AC module available
Display	77 mm x 58 mm viewable LCD graphic display with status indicator lights for easy reading, continuous backlit for ease of viewing indoors and outdoors, available menu languages include English, German, Italian and Spanish
Load Cell Excitation	5 VDC +/-10%, 90 mA
Communication	Standard serial interface RS-232C provides support for modem, RS-485, 2- and 4- wire multi-drop
Communication Protocols	Modbus RTU, Allen Bradley DF-1, Siemens
Ethernet	Ethernet IP and Modbus TCP
Built in USB Port	Configuration and data storage
Expansion Slots (4)	Optional boards include 4-20 mA output board, input/output expansion boards, digital or analog input/output boards, Profibus or Standard communications board. Audit trail standard in every unit.
Ratings	cCSAus, CE

### Ramsey Micro-Tech 9301-D Digitizer Specifications

Digitizer Type	Continuous electronic load cell to digital signal digitizing
Enclosure	NEMA-4, painted mild steel
Power Requirements	100-240 VAC, 50/60 Hz, 20 VA
NTEP Certifiable	NTEP certifiable version includes premium A/D to meet certification requirements

### Ramsey 61-12 Digital Speed Sensor

Type	Digital, brushless
Mounting	Direct to 15.88 mm (0.625 in) diameter stub shaft on tail pulley, bend pulley, or return roll
Housing	Weather-tight, epoxy finish, cast aluminum
Mounting Hardware	Supplied with coupling, restraint arm and restraint spring
Shipping Weight	3.6 kg (8 lb)
Approvals	FM Approved for Class I, Div. 2, Group D; Class II, Div. 1 & 2, Groups E, F & G

[thermoscientific.com/bulkweighing](http://thermoscientific.com/bulkweighing)

© 2015 Thermo Fisher Scientific Inc. All rights reserved. All trademarks are the property of Thermo Fisher Scientific Inc. and its subsidiaries. Specifications, terms and pricing are subject to change. Not all products are available in all countries. Please consult your local sales representative for details.

<b>Australia</b> +61 (0) 8 8208 8200 +61 (0) 8 8234 3772 fax	<b>Chile</b> +56 (0) 2 378 5080 +56 (0) 2 370 1082 fax	<b>India</b> +91 (20) 6626 7000 +91 (20) 6626 7001 fax	<b>South Africa</b> +27 (0) 11-776-0000 +27 (0) 11-822-3982 fax	<b>United States &amp; Canada</b> +1 (800) 445-3503 +1 (763) 783-2525 fax +1 (763) 783-2500 direct
<b>Brazil</b> +55-11-2730-3261	<b>China</b> +86 (0) 80 0810 5118 +86 (0) 21 6445 1101 fax	<b>Italy</b> +39 02-950590-55 +39 02-953200-15 fax	<b>Spain</b> +34 (0) 91-484-5965 +34 (0) 91-484-3597 fax	
	<b>Germany</b> +49 (0) 208-824930 +49 (0) 208-852310 fax	<b>Mexico</b> +52-55-1253-9424 +52-55-3604-0179 fax	<b>United Kingdom</b> +44 (14) 4241 3700	

PI.8108.0715

**Thermo**  
SCIENTIFIC

A Thermo Fisher Scientific Brand