

Thermo Scientific Ramsey IDEA Belt Scale System

Accurate Conveyor Weighing
of Bulk Materials

The Ramsey IDEA Belt Scale System provides basic rate information and totalization functions in processes involving non-critical or lower value materials with an accuracy of $\pm 1\%$. This belt scale system allows you to monitor production output and inventory, or regulate product loadout, while providing vital information for the effective management and efficient operation of your business.

Features

- Economical and accurate
- Single or dual module configurations
- Reliable and easy to use electronics
- Designed for a variety of materials and applications



Specifically designed for operations where economy and ease of installation are important considerations, the Ramsey IDEA Belt Scale System from Thermo Scientific™ is ideally suited for applications in processes involving either non-critical or lower value materials. It provides basic rate and totalization functions that can be used for control and/or production output monitoring.

The Ramsey IDEA Belt Scale System continues Thermo's longstanding tradition of providing high quality, reliable and innovative weighing products to the process industries. Its patented design is the result of many years of experience in thousands of belt scale applications around the world.

How the System Operates

The Ramsey IDEA Belt Scale System consists of three major elements: the weighing assembly, the belt speed sensor, and an electronic integrator.

The weighing assembly consists of either one or two modules, depending on conveyor width. Compact and designed to attach to the conveyor's stringers, the modules support the weigh idler and measure the weight of material on the belt.

The speed sensor is mechanically connected to the conveyor's large diameter tail pulley and generates a stream of pulses. Each pulse represents a unit of belt travel. The frequency of the pulse stream is proportional to belt speed.

The electronics integrate the output signals from the scale module(s) and speed sensor to arrive at a rate of material flow and the total material passed over the scale. The electronics also function as the system's power supply and incorporate all the features that allow calibration, operation and diagnostics for the entire system.



Thermo
SCIENTIFIC

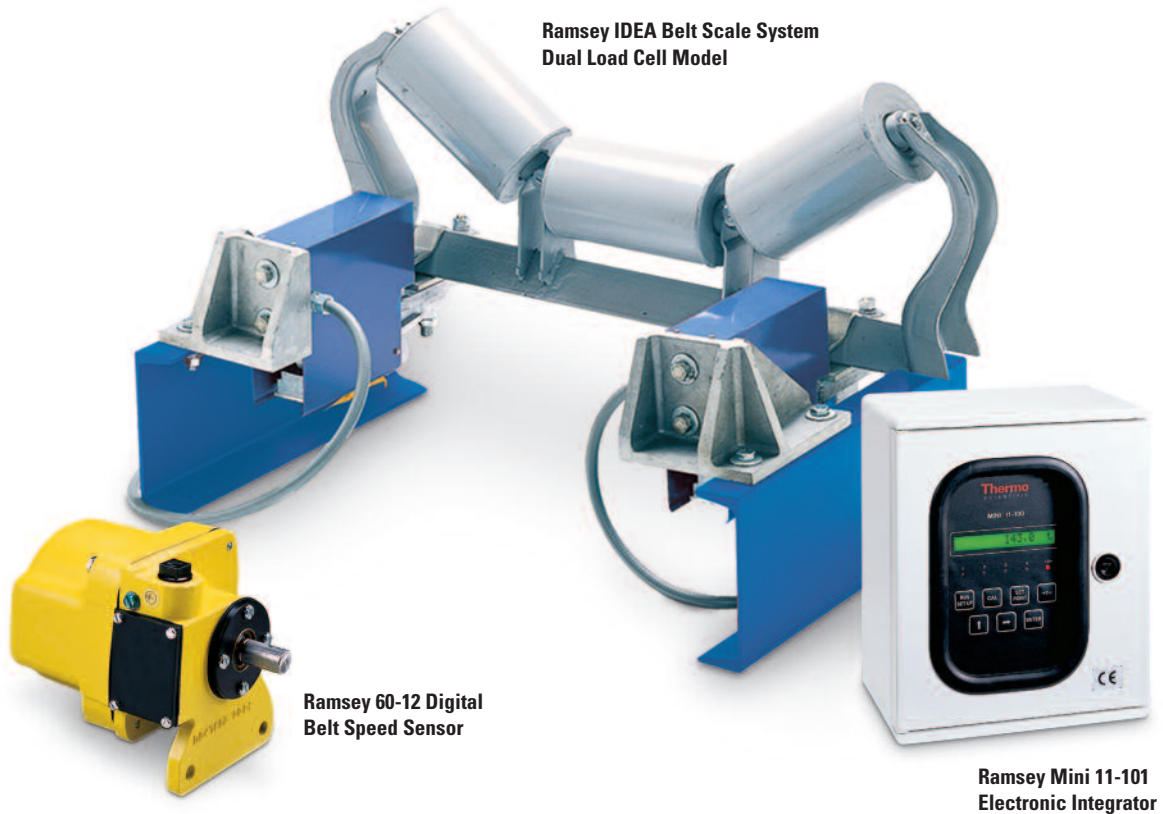

**Ramsey IDEA Belt Scale System
Dual Load Cell Model**

**Ramsey 60-12 Digital
Belt Speed Sensor**

**Ramsey Mini 11-101
Electronic Integrator**

The Scale Modules

The patented Ramsey IDEA Belt Scale from Thermo Scientific is unlike any other single-idler scale. It consists of either one or two completely assembled Ramsey 10-101R Scale Modules. Each module contains a load cell in a pivotless assembly with factory installed and calibrated overload protection.

The system's *single module version* is for use on conveyors with belt widths up to 914 mm (36 in). This scale module mounts to a support beam that spans the conveyor stringers.

The system's *dual module version* is for use on conveyors with belt widths up to 1,524 mm (60 in). The weighing assembly consists of two identical modules with right and left side steel mounting brackets. Each bracket mounts directly to the conveyor stringer with two bolts.

Each module features:

- Factory installed and calibrated overload protection
- Pivotless design with no linkages to introduce errors
- No moving or wearing parts to cause potential maintenance problems
- Compact design for easy installation and alignment
- No place for material to build up and cause measurement errors
- Identical scale modules fit on any belt width and are interchangeable

The Belt Speed Sensor

Thermo's Ramsey 60-12 Digital Belt Speed Sensor is the most reliable and accurate speed-sensing device ever developed for belt scale service. Direct-coupling the sensor to the conveyor tail pulley, snubbing roll, or a large diameter return roller ensures accurate belt-travel readout. No wheels ride on the belt, which eliminates problems related to material build-up and slippage.

The Electronic Integrators

The Ramsey Mini 11-101 Electronic Integrator is a simple, low cost, microprocessor-based integrator. It is easy to operate and has a simple, straightforward calibration procedure. It provides basic information on Rate and Total, and also has indicating LED's for Ready, Alarm Fail, Span Cal, Zero Cal and Run. The Ramsey Mini 11-101 Electronic Integrator comes standard with a 4-20 mA output and is available with an optional serial output that allows the connection of the integrator to a printer.

The Ramsey IDEA Belt Scale System is also available with the powerful and versatile advanced electronics of the Ramsey Micro-Tech 9000 Series of Electronic Integrators. These integrators have expanded features and options to address more complex requirements.

Performance Guarantee

On factory-approved installations, we warrant that the Ramsey IDEA Belt Scale System will weigh and totalize to a value within $\pm 1\%$ of the test value when calibrated against a known test weight, chain, or Thermo's standard electronic calibration.

The test rate must be between 33% and 100% of the scale system's calibrated capacity. Test duration is defined as at least three circuits or revolutions of the belt, at least 400 counts on the master totalizer, and at least six minutes running time. Its warranty is subject to the scale system being installed, operated and maintained in accordance with factory instructions.

Ramsey 10-101R-1 Single Load Scale Module Dimensions

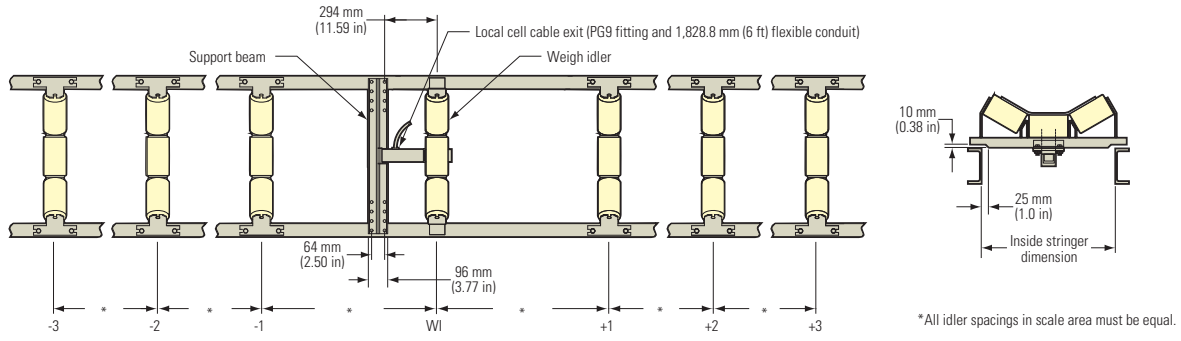

Belt Travel →

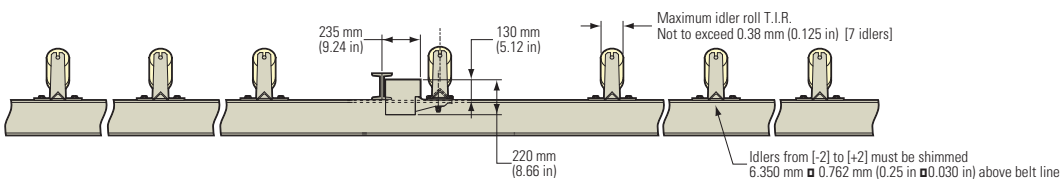

Ramsey 10-101R-2 Dual Load Scale Module Dimensions

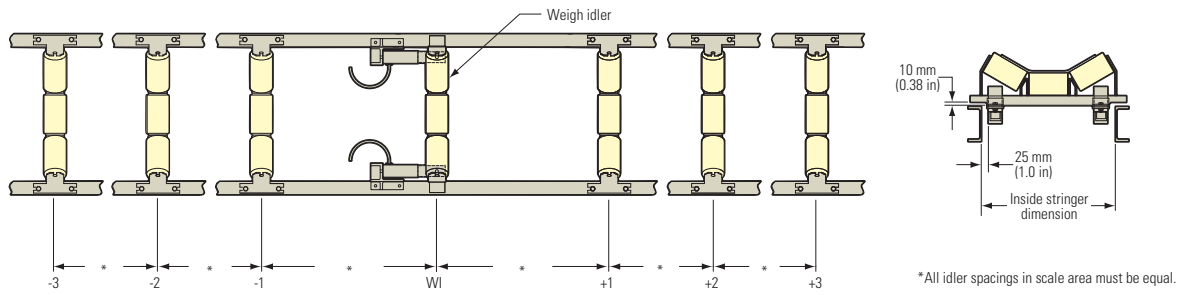

Belt Travel →

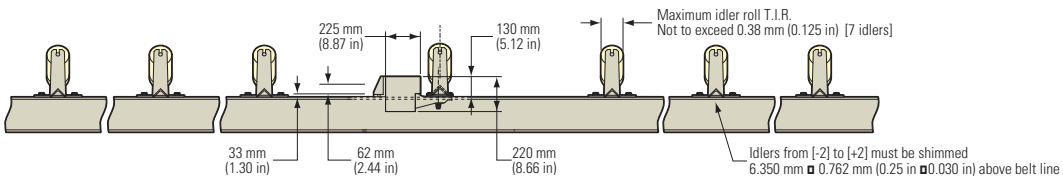

Thermo Scientific Ramsey IDEA Belt Scale System

Ramsey 10-101R Scale Modules

Minimum Net Load at Rated Capacity	15% of load cell capacity
Maximum Gross Load at Rated Capacity	80% of load cell capacity
Available Load Cell Sizes	20 kg (44 lb), 50 kg (110 lb), 100 kg (220 lb), 200 kg (441 lb), 250 kg (551 lb), 500 kg (1,102 lb)
Maximum Belt Width	Ramsey 10-101R-1: 914 mm (36 in) Ramsey 10-101R-2: 1,524 mm (60 in)

Load Cell

Load Cell	Welded bending beam type load cell
Load Cell Output	2.0 mV/V; $\pm 0.1\%$
Excitation	10 VDC or VAC
Load Cell Rating	3000 d; Meets OIML R60 & NIST HB-44
Temperature Range	-30°C to +80°C (-22°F to +176°F) safe; -10°C to +40°C (+14°F to +104°F) compensated
Overload	150% of rated capacity
Input Impedance	380 ohms ± 10
Output Impedance	350 ohms ± 3
Environmental Protection	Hermetically-sealed; IP67
Load Cell Construction	Stainless steel
Cable	6 conductor, shielded, 22 AWG

Ramsey Mini 11-101 Electronic Integrator**Field Mount Enclosure**

Size	300 mm (11.81 in) high x 250 mm (9.84 in) wide x 160 mm (6.30 in) deep
Material	Polyester
Weight	4 kg (8.8 lb)
Protection	IP 65; NEMA 4

Environmental Specifications

Operating Temperature	-10°C to +50°C (+14°F to +122°F)
Storage Temperature	-20°C to +70°C (-4°F to 158°F)
Overall Humidity	<90% without condensation

Power Requirements

Voltage	110 or 220 VAC selectable standard; +10%-15; at 50-60 Hz; 15 VA
Protection	Internal fuse

Inputs and Outputs

Analog Inputs	Mv signal from load cell
Analog Outputs	Quantity: 1 Type: 0-20 mA, 4-20 mA, 20-0 mA, 20-4 mA selectable Maximum Load: 500 ohm Resolution: 12 bit; 4,096 divisions Linearity: 0.1% Insulation: Galvanic; 1,500 Vrms
Digital Inputs	Quantity: 3 Type: Static; For dry contact or open collector Insulation: Optical; 2,500 Vrms; UL E67349 Voltage: 14 VDC internal source Current: 6 mA
Digital Outputs	Quantity: 4 Type: Relay; Dry contact; N.O. Insulation: Galvanic; 10,000 M-ohm Max. Voltage: 240 VAC or 48 VDC Max. Current: 0.5 A
Communication Ports	Quantity: 1 Port: RS 232C for printer use only

Ramsey 60-12 Belt Speed Sensor

Type	Digital, brushless
Mounting	Direct to 15.88 mm (0.625 in) diameter stub shaft on tail pulley, bend pulley, or return roll
Housing	Weather-tight, epoxy finish, cast aluminum
Mounting Hardware	Supplied with coupling, restraint arm and restraint spring
Shipping Weight	3.6 kg (8 lb)



thermoscientific.com/bulkweighing

© 2014 Thermo Fisher Scientific Inc. All rights reserved. Results may vary under different operating conditions. Specifications, terms and pricing are subject to change. Not all products are available in all countries. Please consult your local sales representative for details.

Australia

+61 (0) 8 8208 8200
+61 (0) 8 8234 3772 fax

Brazil

+55-11-2367-2192
+55-11-2367-2192 fax

PI.8054.0514

Chile

+56 (0) 2 378 5080
+56 (0) 2 370 1082 fax

China

+86 (0) 80 0810 5118
+86 (0) 21 6445 1101 fax

Germany

+49 (0) 208-824930
+49 (0) 208-852310 fax

India

+91 (20) 6626 7000
+91 (20) 6626 7001 fax

Italy

+39 02-950590-55
+39 02-953200-15 fax

Mexico

+52 (55) 1253 9410
+52 (55) 1253 9424 fax

South Africa

+27 (0) 11-822-4120
+27 (0) 11-822-3982 fax

Spain

+34 (0) 91-484-5965
+34 (0) 91-484-3597 fax

United Kingdom

+44 (14) 4241 3700

United States & Canada

+1 (800) 445-3503
+1 (763) 783-2525 fax
+1 (763) 783-2500 direct

Thermo
SCIENTIFIC

Part of Thermo Fisher Scientific