

**Overview**

Milltronics TASS is a compact low-profile, wheel-driven return belt speed sensor, ideal for use on mobile crushers and in constricted spaces.

**Benefits**

- Rugged design
- Easy, low cost installation
- Compact, low-profile speed sensor
- IP67 rated

**Application**

Milltronics TASS speed sensor operates in conjunction with a conveyor belt scale, providing signals to an integrator (Milltronics BW500, or SIWAREX FTC) which computes the rate of material being conveyed. The trailing arm speed sensor monitors conveyor belt speed, with the output signal transmitted by cable connection to the integrator.

Easily installed close to the belt scale assembly, the TASS provides a signal generated as the wheel rotates on the return belt. Pulses are generated by the internal proximity switch detecting the rotation of the five spoked wheel. The TASS is mounted to the static beam of the belt scale or to a structural cross member via a pivoting bracket assembly.

The TASS is a compact, low-profile, rugged speed sensor, most often used on mobile crusher applications where space is limited. The TASS output can be applied to any Milltronics belt scale integrator.

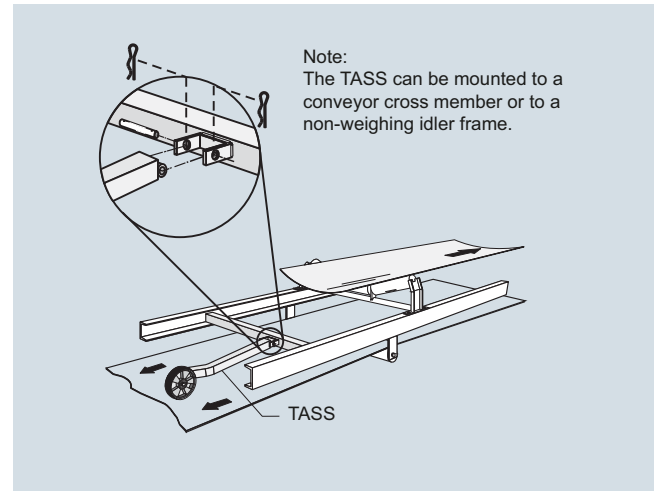
**Design**

TASS Installation

**Technical specifications**

<b>Milltronics TASS</b>	
<b>Mode of operation</b>	
Measuring principle	Inductive proximity sensor provides pulse to integrator
Typical application	Mobile crusher
<b>Input</b>	<ul style="list-style-type: none"> <li>• Bi-directional wheel rotation</li> <li>• 25 ... 350 rpm</li> </ul>
<b>Output</b>	<ul style="list-style-type: none"> <li>• Open collector, NPN, sinking output, max. 200 mA</li> <li>• Pulses: 5 per revolution</li> <li>• 9.947 pulses/m, 3.03 pulses/ft</li> </ul>
<b>Rated operating conditions</b>	
Operating temperature	-25 ... +70 °C (-13 ... +158 °F)
Max. belt speed	3 m/s (590 fpm)
Degree of protection	IP67
<b>Design</b>	
Trailing arm assembly	Painted mild steel
Wheel	160 mm (6.3 inch) diameter cast aluminum with polyurethane tread
<b>Power supply</b>	10 ... 35 V DC, 15 mA at 24 V DC maximum
<b>Wiring</b>	
Brown	+ Excitation (10 ... 35 V DC)
Black	+ Signal
Blue	- Common
<b>Interconnection wiring (to integrator)</b>	<ul style="list-style-type: none"> <li>• 5 m, 3 conductor shielded PVC cable, 3 x 0.25 mm<sup>2</sup> (23 AWG), protected with 1 000 mm of flexible conduit</li> <li>• 300 m (1 000 ft) maximum cable run</li> </ul>
<b>Approvals</b>	CE, RCM, EAC, KCC

# Belt Scales

## Speed sensors

### Milltronics TASS

#### Selection and ordering data

##### Milltronics TASS speed sensor

Compact, low-profile, wheel driven return belt speed sensor for belt conveyors; ideal for use on mobile crushers and in constricted spaces.

➤ Click on the Article No. for the online configuration in the PIA Life Cycle Portal.

##### Model

5 pulses per revolution

##### Fabrication

Standard, C5-M rated polyester painted mild steel

Stainless steel 304 (1.4301), bead blast finish (1 ... 6 µm, 40 ... 240 µin)

Note: wheel is aluminum for all versions

##### Mounting options

Complete with standard mounting kit

##### Approvals

CE, RCM, EAC, KCC

Article No.

7MH7131-

0

1

A

B

A

1

Order Code

##### Further designs

Please add "-Z" to article no. and specify order code(s).

Stainless steel tag [69 x 38 mm (2.7 x 1.5 inch)]  
Measuring-point number / identification (max 27 characters), specify in plain text.

Y15

Manufacturer's test certificate:  
According to EN 10204-2.2

C11

##### Operating instructions

All literature is available to download for free, in a range of languages, at

<http://www.siemens.com/weighing/documentation>

##### Spare parts

TASS wheel

Article No.

7MH7723-1AN

TASS proximity switch

7MH7723-1AP

TASS wheel, stainless steel sealed bearing

7MH7723-1GW

Conduit replacement kit

7MH7723-1NA

#### Dimensional drawings

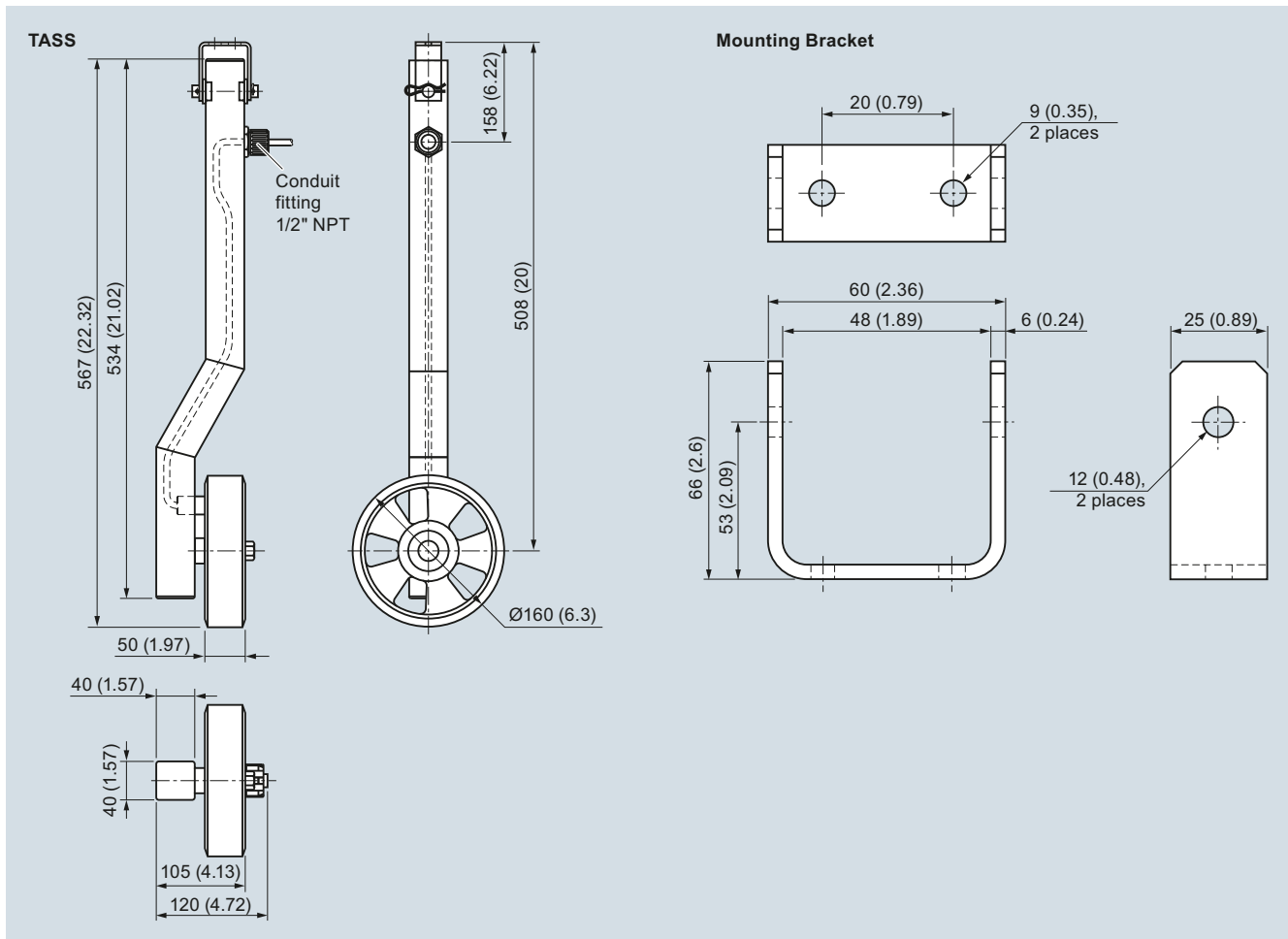

TASS, dimensions in mm (inch)