

GE

PTX 300 Series

Druck Subsea Pressure Transmitters

The PTX 300 series of pressure transmitters has been developed for the offshore oil and gas industries as a compact, high performance device for reliable and long term subsea use. Maintenance free, it is available with operating ranges up to 1035 bar and is fully submersible with an ambient pressure rating up to 300 bar or 3000m H₂O.

Originally designed for aerospace hydraulic systems, the PTX 300 series utilizes micromachined piezo-resistive silicon pressure measurement technology, continually developed and proven for 30 years.

The product is packaged to suit the specific requirements of subsea hydraulic control systems. In particular, the high pressure containment rating, hydraulic transient protection and integrity of cable/electrical connections combine with the precision measuring technology to make the PTX 300 series a leader in this field.



Features

- Ranges from 70 to 1035 bar
- External/ambient pressure up to 300 bar
- Better than 0.1% accuracy
- High reliability and excellent long term stability
- All Electron Beam welded construction
- Reverse Polarity Protected
- Sensors are marked with both 'CE' and 'ROHS 50 Years' for the China Market.



Installation Drawings

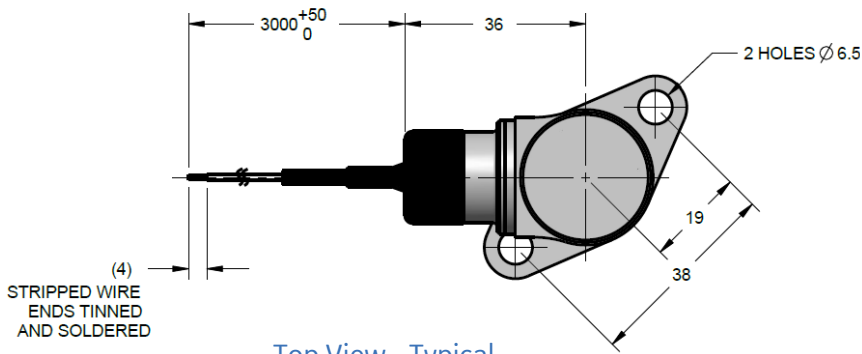

Top View - Typical

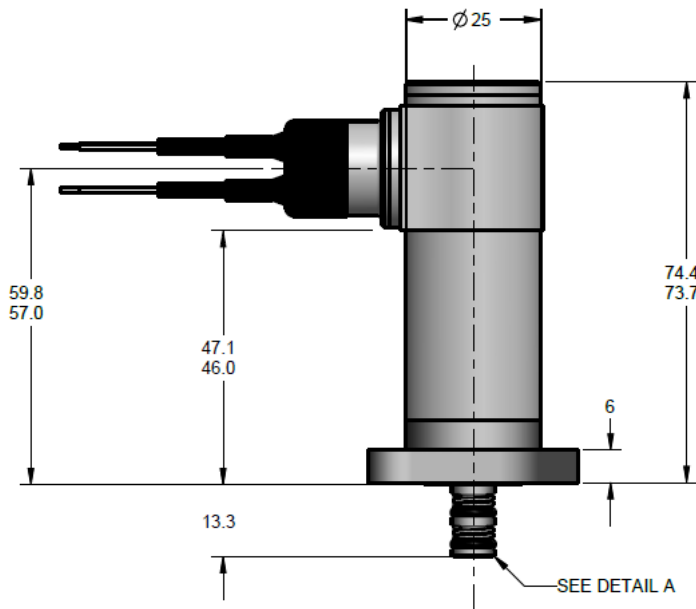

Spigot Pressure Connection

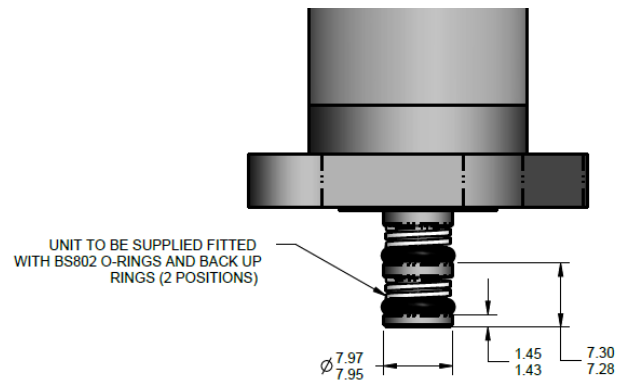

DETAIL A - SEALING O-RINGS

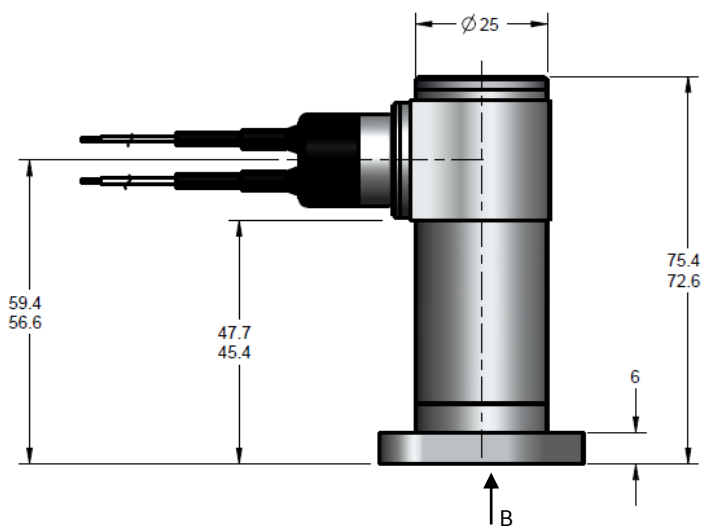

Flat Face Pressure Connection

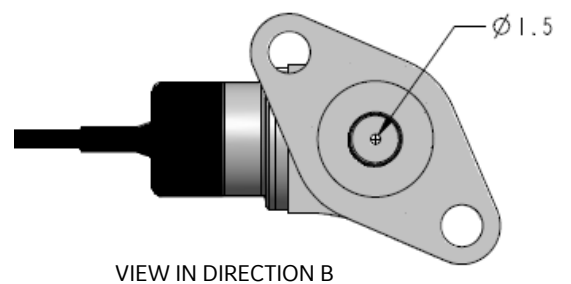

All Dimensions in mm

PTX 300 Specifications

Pressure Measurement

Operating Pressure Ranges

A full scale (FS) pressure range may be specified between 0 - 228 bar and 0 - 1035 bar, sealed gauge (See ordering information for available ranges).

Proof Pressure

Proof pressure tested to 1.5 x FS pressure

Overpressure

The operating pressure range can be exceeded by 1.5 x FS pressure to 1600 bar max, whichever is less.

Secondary Containment Pressure

The transmitter will safely contain up to 1150 bar maximum without leakage of pressure media.

External Case Pressure

Tested to 300 bar with negligible change in calibration.

Pressure Media

Fluids compatible with a fully welded assembly of Inconel 625 and Stainless Steel.

Transmitter Supply Voltage

10 to 32 VDC. The minimum supply voltage that must appear across the transmitter terminals is 10 VDC. and is calculated by: $V_{MIN} = V_{SUP} - (0.02 \times R_{LOOP})$

Supply Sensitivity

<0.005% F.S./Volt.

Insulation Resistance

>100M Ohm @ 500 Vdc

Output Current

4 to 20mA (2-wire) proportional for zero to full scale pressure.

Performance

Accuracy

Combined Non-linearity, Hysteresis and Repeatability: $\pm 0.1\%$ F.S. B.S.L.

Zero Offset and Span Setting

$\pm 1\%$ F.S. nominal at 23°C.

Long Term Stability

At standard reference conditions, any calibration change will not exceed 0.1% F.S. per annum.

Temperature Range

Process/ambient -20 to 40°C
Compensated -20 to 40°C
Storage -30 to 50°C

Temperature Effects

$\pm 0.5\%$ F.S. Total Error Band.

Physical

Pressure Connection

Face or Spigot with O-ring seal connection.

Electrical Connection

Flying lead 3m long with striped ends, prepared by tinning and soldering. Cable type Raychem FLHTC0311-0.35

Weight

Approx 270 grams nominal.

Ingress Protection

IP68, submersible to 3000m H₂O.

Documentation

Sensor is supplied with a Certificate of Conformance. An MRB is available for this range of sensors. If required please order item '123M8389-1 MRB for PTX300' as a separate line item on the Purchase Order.

Ordering Information

Value	Description	PTX300	-	*	-	***
Main Product Variant						
PTX300	...	4-20 mA Pressure Transmitter				
Pressure Connector						
1	...	Spigot				
2	...	Flat Face				
Pressure Range						
228	...	228 bar sealed gauge				
379	...	379 bar sealed gauge				
569	...	569 bar sealed gauge				
690	...	690 bar sealed gauge				
759	...	759 bar sealed gauge				
1035	...	1035 bar sealed gauge				

Please state the Part Number required from the above table:

Related Products

The PTX 300 series is also available to suit individual user requirements. Please refer to GE Sensing & Inspection Technologies.

GE Sensing & Inspection Technologies manufactures a comprehensive range of pressure sensors, indicators, calibrators, controllers and deadweight testers.

Please refer to GE for further information and product datasheets.

Calibration Standards

Instruments manufactured by GE Sensing & Inspection Technologies are calibrated against precision pressure calibration equipment which is traceable to International Standards. Continuing development sometimes necessitates specification changes without notice.

